



## BSKF-R

### HARİCİ MOTORLU DİKDÖRTGEN KANAL FANI Öne Eğimli

Bahçivan BSKF-R dikdörtgen kanal fanları uygulama alanının sınırlı olduğu sistemlerde düşük ve orta hacimde havalandırma ihtiyaçlarının karşılanması için tasarlanmıştır. Motor hava akımı dışarısında olduğundan dolayı 120° sıcaklığa kadar dayanıklıdır.

#### Teknik Resim

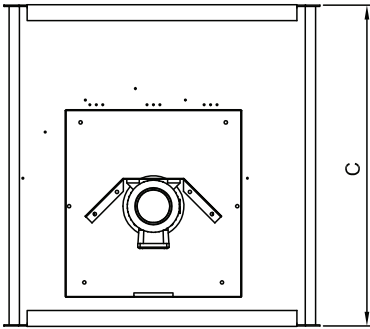
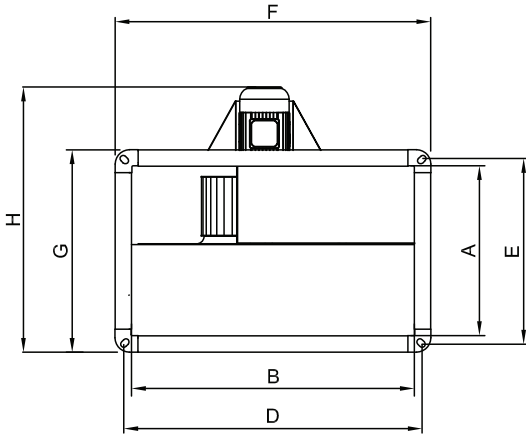

#### MALZEME

: Gövdesi galvaniz, radyal fan, sık kanat yapısı ile galvaniz sac'dan üretilmiştir.

#### YALITIM SINIFI

: ClasF

#### STANDART

: EN 60335-1, EN 60335-2-80

#### HIZ KONTROLÜ

: Opsiyonel kontrol cihazıyla sağlanabilir.

#### KULLANIM ALANLARI

: Mutfak aspiratörleri, otel, araba, park ve kamu binaları, alışveriş merkezleri vb. alanlarda kullanıma uygundur.

TİP	A	B	C	D	E	F	G	H
BSKF-R 200	200	400	500	420	220	450	250	469
BSKF-R 225	250	500	560	520	270	550	300	519
BSKF-R 250	300	500	560	520	320	550	350	589
BSKF-R 280	300	600	710	620	320	650	350	589
BSKF-R 315	350	600	710	620	370	650	400	684
BSKF-R 355	400	700	780	720	420	750	450	766
BSKF-R 400	500	800	880	820	520	850	550	866
BSKF-R 450	500	1000	980	1020	520	1050	550	886

Ölçüler mm cinsindedir.

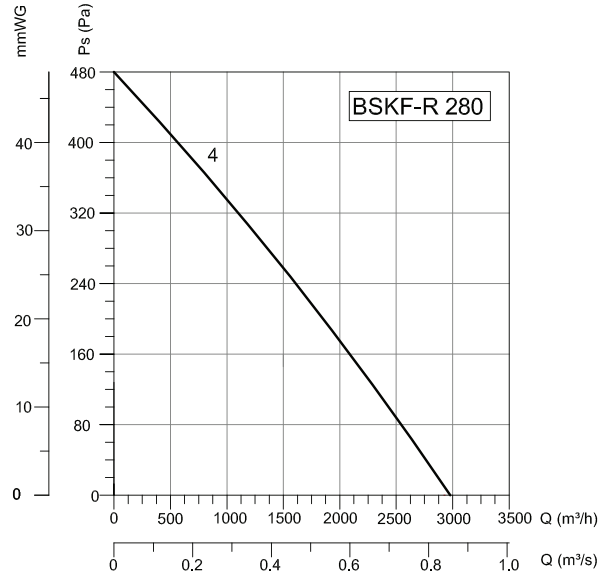
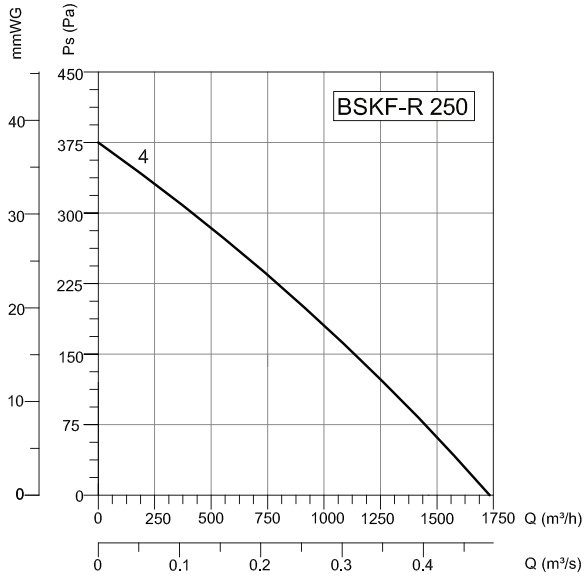
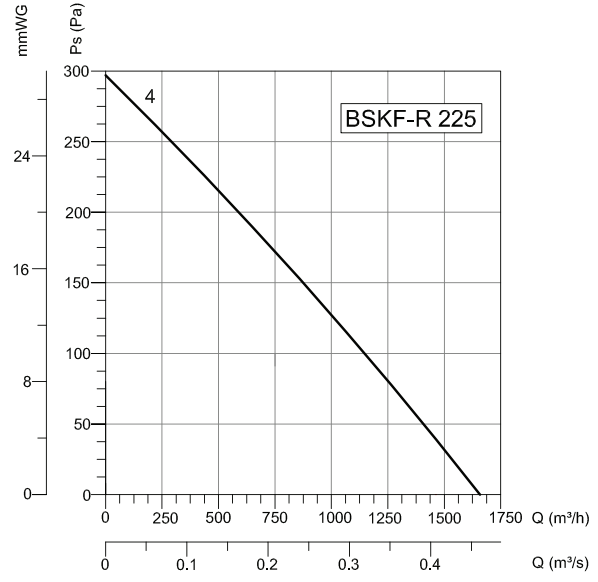
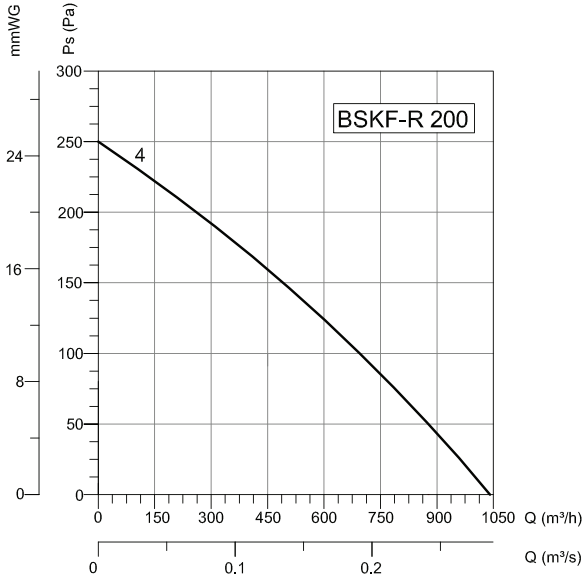

TİP	VOLTAJ	FREKANS	GÜÇ	AKIM	DEVİR	DEBİ	AĞIRLIK
	V	Hz	Kw	(A)	d/d	m <sup>3</sup> /h	kg
BSKF-R 200-4	230/380	50	0,25	1,8/0,81	1400	1000	22
BSKF-R 225-4	230/380	50	0,37	2,6/1,15	1400	1673	35
BSKF-R 250-4	230/380	50	0,55	3,3/1,5	1400	1740	40
BSKF-R 280-4	230/380	50	0,75	4,6/2	1400	2942	43
BSKF-R 315-4	230/380	50	1,5	9,3/3,5	1400	4050	55
BSKF-R 315-6	380	50	0,37	1,1	900	2650	52
BSKF-R 355-4	230/380	50	2,2	13,4/5,1	1400	8000	85
BSKF-R 355-6	380	50	1,1	3	900	5200	81
BSKF-R 400-6	380	50	1,5	3,5	900	6000	92
BSKF-R 450-6	380	50	2,2	5,1	900	7500	120

# KANAL FANLARI

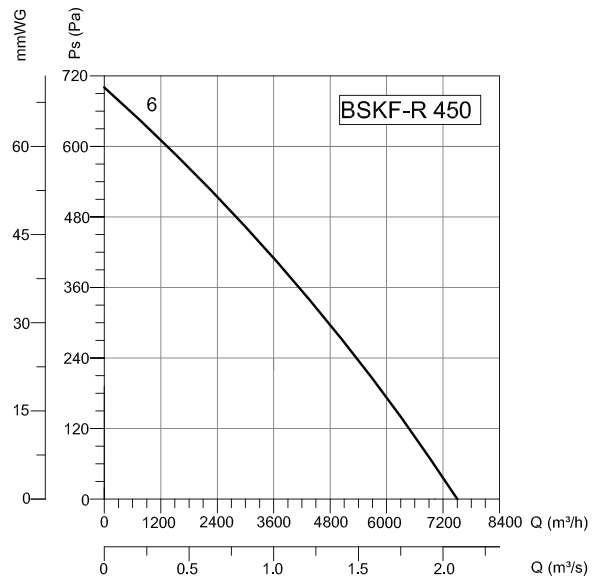
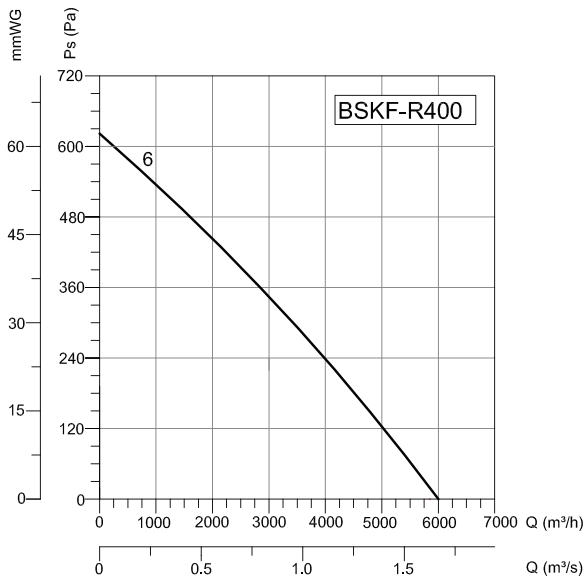
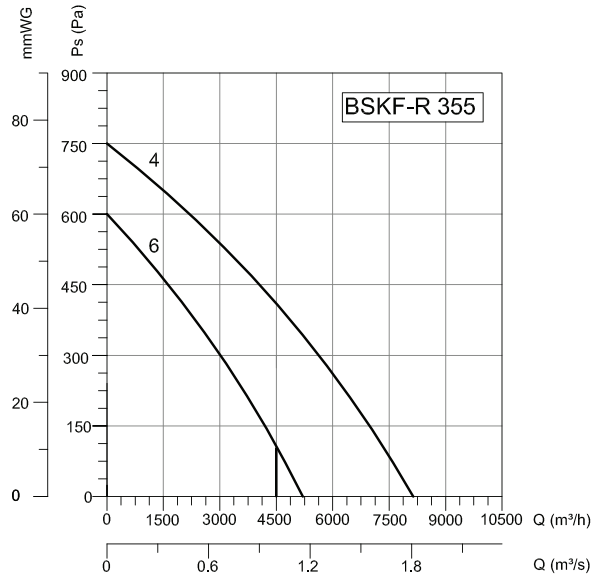
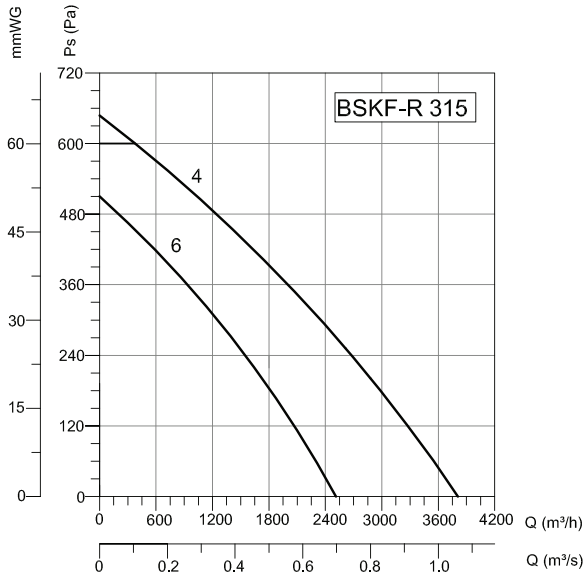

## Aksesuarlar



**BSC**



**BSC-F**

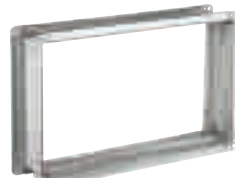

**BDEB**

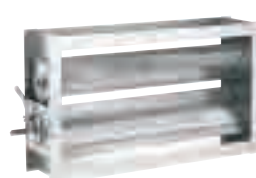

**BDH**



**BDKS**



KANAL FANLARI

ÇATI FANLARI

AKSIYEL FANLAR

RADYAL FANLAR

PLASTİK FANLAR

VANTİLATÖRLER

DUMAN EGZOST  
SİSTEMLERİ

AKSESUARLAR